



**LET'S
ROCK
DABOMB**
COMMAND CENTRAL
www.dabombbike.com
info@dabombbike.com

AUTHORIZED DEALER

WHO HAS **THE BEST**
WEAPON
 FRAMES &
 BIKE COMPONENTS
 WEAPON GUIDE



**LET'S
ROCK
DABOMB**

THE BEST WEAPONS AT DA BOMB!!!

Da bomb has been on the market for more than 18 years. We specialize in the **Heavy-Duty MTB** such as Downhill, Freeride, Dirt Jump, Slope Style, Enduro and All Mountain. Since we started our goal was to make top quality frames and components that are up to date with the latest technological developments and mountain biking trends.

The Da Bomb components are designed from people that are passionate riders. We listen and we feel the needs and the demands of riders worldwide and that makes Da Bomb strive to produce better products.

Da Bomb sponsors many mountain bike events and competitions throughout the world. We collect valuable experience and information through our interaction with racers and riders and we implement that continuous feedback evolving our products.

Now, get ready to have your heart blown away for 2017 DA BOMB collection introduced.



www.DABOMBIKE.COM

WEAPON SELECTION

SPONSORSHIP 4

SWEDEN-SPONSORED RIDER-
NIKLAS WALLNER - GRASSROOTS
BELGIUM SPONSORED RIDER-
DAVID DERYCK
FRANCE SPONSORED RIDER-
ROBIN CHARPENTER - REDOINE DJELLOUDI BERGEN

FRAMES 6

FOAB BOMB 26/275
BLITZ 5.5
EMP ATTACK 275/29ER
REVOLUTION 26
SONIC BOOM 26
STRIKER 275
EXPLODE 275

COMPONENTS 12

IMPACT STEM 12
TRIBAL HANDLEBARS 14
HEADSET 16
GRIPS 17
SEATPOSTS 18
HUB SETS 20
RIMS/ RIM TAPE 22
SADDLES 24
PEDALS 25
RECOIL 26

JUMPING BIKE KITS 27

X-RING / SCROLL / SPROCKET

APPAREL 29

BEANIE / BANNER / BOMB FENDER/ TEAM JERSEY /
DABOMB TEE/

ACCESSORIES 29

BOMB BOY WATER BOTTLE
GRENADE VALVE/ CROSS VALVE/
SKULL VALVE/ STICKER SET/
AUTHORIZED DEALER STICKER

SPECIFICATION 31

FRAME GEOMETRY CHART

SPONSORSHIP

Sponsored Rider *Sweden*

NIKLAS WALLNER

RIDER PROFILE: NIKLAS WALLNER

3rd Scandinavian downhill cup, Vallåsen 2016
 43rd Enduro world series, Whistler, Canada 2015
 19th garbanzo downhill Crankworx, Whistler 2015
 49th World championships, Hafjell, Norway 2014
 16th Hafjell world cup 2013
 Swedish national champion 2012
 Getting back riding and racing after having punctured my spleen in 2010.

Niklas Wallner is turning 26 this year and has been racing downhill for many years. The majority of his career has been on Da Bomb bikes, from taking his first national title in 2006 to getting his first top 20 in the world cup. With almost 8 years on the world cup circus Niklas decided to change it up a bit and put more focus into filming and photographing this year compare to other years. He will also be racing the Scandinavian downhill cup and a couple of selected enduro races in Sweden.



GRASSROOTS PROJECT

Da Bomb Bikes gives the supports on bike industry as always, this year, Da Bomb Bikes involves in Grassroots Project, which was innovated by a team of Sweden passionate riders. These riders train the young riders in any level with their experience and

professional riding tricks, and the project is also handled by the famous rider Robin Waller as well. Da Bomb Bikes dedicate ourselves on the riders development, step by step, make our best effort on MTB.

Sponsored Rider *Belgium*

DAVID DERYCK

RIDER PROFILE: DAVID DERYCK

2015- 4x Pro Tour Malmedy Men (2nd place)
 2015- 4x Dirtmasters Europe Men (10th place)
 2014- DH1 International Men's Elite (Top 50)
 2013- Dirts Whip Off contest (1st Place)
 2012- National 4x/Dual Slalom Belgium (3rd place)
 2012- Belgian Championship DH Elite (14th place)

Around 2010, David Deryck from Belgium found himself in love with mountainbiking, started with an old mountainbike and going to small local jump spots and skateparks to racing downhill and dual slalom events all over the country and further. It's no longer a hobby now, it's a lifestyle. Ending up on the podium on one of the first races he competed in got him motivated to keep progressing in this sport and never stopped since.

"Thanks to the sponsorship of Da Bomb I get to focus on travel and racing as much as I can. All I think about when I wake up is riding bikes!" David. He has the motivation to become one of the fastest guys out there and Da Bomb is helping to make this dream come true. He never gets bored and always with a big smile on a personal quest to become the fastest man out there!



Sponsored Rider *France*

ROBIN CHARPENTIER

RIDER PROFILE-ROBIN CHARPENTIER

1st FISE Xperience AM - Reims 2015
 4th H2P Rambouillet contest 2015
 12th Kunterbunt PRO contest 2015
 1st Jam Venette 2014
 4th Jam Venette 2013
 4th Jam Venette 2012
 3rd Jam Venette 2011
 15th FISE Montpellier 2011

"I'm 21 years old, I live in France and I'm Professional Mountain Biker. I started cycling at the age of 15 years old in 2010 after watching an international biking event Crankworx Whistler on TV. I ride on local dirt spots with my friends to feel this atmosphere of freedom and fun that surround us but lately I've decided to spend time in Spain at La Poma Bike Park to train and diversified my tricks.

This year, I ride on the SONIC BOOM a frame very easy to handle and lovely with geometry / lightness remarkable, I also roll on DH frame of FOAB BOMB which is great with exceptional stability and response peerless in the different tracks.

This opened the doors to the world of DH and freeride in which I intend marked my trail. " I am proud to represent DA BOMB Bikes is a company which I feel at ease not just with the bikes but also their spirits to always improve and developed this product ! "This year I am preparing for several events of the FMB World Tour in Europe and also for my first races DH in Belgium. I do a lot of physical preparation but also such Crossfit building, motorcycle MX...I like to give the best of myself in every field, my goal is primarily to enjoy myself but also to grow and to showcase our sport through videos and demonstrations. "



Sponsored Rider *France*

REDOINE DJELLOUDI-BERGEN

RIDER PROFILE-REDOINE DJELLOUDI-BERGEN

2015 PumpTrack Kunterbunt contest (6th place)
 2014 Jam, Venette (14th place)

I started quite early in the DJ during my early days, I've known DA BOMB who was also at the cutting edge of technology, seeing the evolution of MTB, DA BOMB has imposed his style !

" Having integrated the team DA BOMB both an honor and a challenge for me! The spirit of the team DA BOMB is totally my constantly since the desire and the need to improve the products. The frame SONIC BOOM allowed me to have a new approach of DJ thing I convey to young kids who want to progress in the MTB! It opens a perfect freedom of movement with a geometry and ease foolproof. "

The MTB is not just a sport beyond it's a lifestyle, what I like in the MTB is the discovery, traveled and the sense of sharing that surrounds us, chill out with friends during a session that's the magic of MTB !

It is fortunate for me to share the tricks with my teammate Robin C, who brings me a lot of good advices and we travel and share our spirits of discovering. Our passion and share with the people.



FOAB BOMB 26 / 27.5

DOWNHILL

The FOAB BOMB frame is DA BOMB's best downhill weapon.

The frame is made out of hydro formed aluminum to provide a very responsive front end but also a very stiff rear end. It can be set for 26" & 27.5" wheels and has adjustable chain stay length from 435 to 445mm. The long wheelbase length together with the lower center

of gravity provides confidence in high speed turns. Bigger size bearings in the suspension link ensure smooth linkage-suspension operation and ability to absorb big impacts.

The FOAB BOMB can handle the toughest downhill tracks-bikeparks and it can be the ultimate downhill weapon in your hands!

Dual Mode Control of Chainstay Available in 435/445 mm.
Applicable With 26" and 27.5" Wheel Sets.
Hydro-forming Tube.

Size: 16.5"
Tapered Head Tube 1-1/8"(ZS44)/1.5"(ZS56)
Travel: 8 inches
Shock: ROCK SHOX KAGE L240*TR75*M8 (FW22.2+RW22.2)
(DaBomb reserves the right to change the shock)

Seat Post: 30.9 mm
BB Width: 83mm
Chain Guide: ISCG 05
Rear Dropout: 150mm X 12mm
Weight: 5100g
Color Available: Orange, Neon Yellow, Matte Black



BLITZ 5.5

AM/ENDURO

Da Bomb brand new full carbon suspension frame, due to carbon material use and the produce technology has been stability and mature, so Da Bomb first time use carbon material for frame Products provide unprecedented of light weight and typical in your ride feeling.

Full Carbon Four-bar Linkage Frame.
Intergraded Cable Routing.

Size: 17", 19"
Tapered Head Tube 1-1/8"(ZS42)/1.5"(ZS52)
Travel: 5.5 inches
Shock: X-Fusion O2-RL L190*TR49*M8(FW22.2+RW22.2)
(DaBomb reserves the right to change the shock)
Seat Post: 31.6 mm
BB Spec.: BB 92
Rear Dropout: 142mm X 12mm
Weight: 1900g (W/O Shock)
Color Available: Black



EMP ATTACK 275

AM

When it comes to all mountain, EMP Attack 275 is the best weapon of choice. With its light hydroformed frame, four bar linkage suspension, 142mm rigid rear end, choice of suspension travel set up at 4.7 and 5.4 inches you can pedal up hills, ride all day backcountry, shred enduro and dh trails or even hit the bikepark. EMP's set up versatility and confidence inspiring geometry will help you attack faster your favorite trails. This is definitely going to be your favorite all mountain machine.

Dual travel Alternative at 4.7" and 5.4"

142mm QR Thru Axle

Direct Mount Front Derailleur

Size: 16", 18"
 Tapered Head Tube 1-1/8" (ZS44)/ 1.5" (ZS56)
 Travel: Dual alternation at 4.7" and 5.4"
 Shock: X-Fusion O2-RL L190*TR49*M8(FW22.2+RW52)
 (DaBomb reserves the right to change the shock)
 Seat Post: 30.9mm
 BB Width: 68mm
 Chain Guide: ISCG 05
 Rear Dropout: 142mm X 12mm
 Weight: 3500g (with shock)
 Color Available: Matte Black, Yellow, Grey



EMP ATTACK 29ER

XC-AM

Big wheel reacts to an extremely stable performance. The EMP ATTACK 29ER is talented to cross the most difficult roads, no matters on rocks, gravels or sandy trails are all under your control. We took our EMP ATTACK 26" to rework the frame sizing and geometry to appropriately accommodate 29" wheels, Since then 29ER is the best weapon to conquer any obstacles.

29ER Low Gravity Design.

29ER Extremely Stable Feature

Direct Mount Front Derailleur

Size: 18"
 Tapered Head Tube 1-1/8" (ZS44)/ 1.5" (ZS56)
 Travel: 4.2 inches
 Shock: X-Fusion O2-RL L190*TR49*M8(FW22.2+RW52)
 (DaBomb reserves the right to change the shock)
 Seat Post: 30.9mm
 BB Width: 68mm
 Chain Guide: ISCG 05
 Rear Dropout: 135mm X 10mm
 Weight: 3480g
 Color Available: Matte Black



REVOLUTION 26 SLOPE STYLE

The REVOLUTION 26" frame is a classic among Slope Style and Dirt Jump riders. It uses the proven four bar linkage suspension and together with its rigid aluminum 7005 double butted frame, tapered head tube, short wheelbase, 142mm stiff rear end it can be a mean "trick machine". Extra features include gear shifter to be placed on the frame allowing maneuverability for bar spins, ISCG 05 chain guide if you wish to use gears, front direct mount derailleur.

Four Bar Linkage Stiff Slope Design

142mm QR Thru Axle

Direct Mount Front Derailleur

Aluminum 7005 Double Butted Tube

Size: 26"x13.5"
 Tapered Head Tube 1-1/8" (ZS44)/ 1.5" (ZS56)
 Travel: 4 inches
 Shock: X-Fusion O2-RL shock
 L165*TR38*M8(FW22.2+RW22.2)
 Seat Post: 30.9mm
 BB Width: 73mm
 Chain Guide: ISCG 05
 Rear Dropout: 142mm X 12mm
 Weight: 3321g
 Color Available: Bright Black, Neon Yellow, Royal Blue



SONIC BOOM 26

DJ / STREET

When you ride into the Dirt jump, to enhance supportability from entire frame is necessary, Sonic Boom frame brings high performance and typical design such as length of chain stay had been shortest than before provides excellence in control for rider, and the rear dropout with a screw bolt in order to adjustment of chain tension, also we have component of HCT (Horizontal Chain Tension) for optional it. Besides, if you want to upgrade from single speed to multiple derailleur system, the D-HANGER would be a great assistance to solve it. Build one for yourself and see you down the trails.

Shorten Wheelbase Design.
Strong And Stiff CNC Hardtail Frame.

Size: 26"x12.4"
 Taper Head Tube: 1-1/8"(ZS44) / 1.5"(ZS56)
 Seat Post: 30.9mm
 BB Width: 73mm
 Chain Guide: ISCG 05
 Rear Dropout: 135 mm x 10mm
 Weight: 1976g
 Colors Available: Matte Black, Neon Yellow, Blue

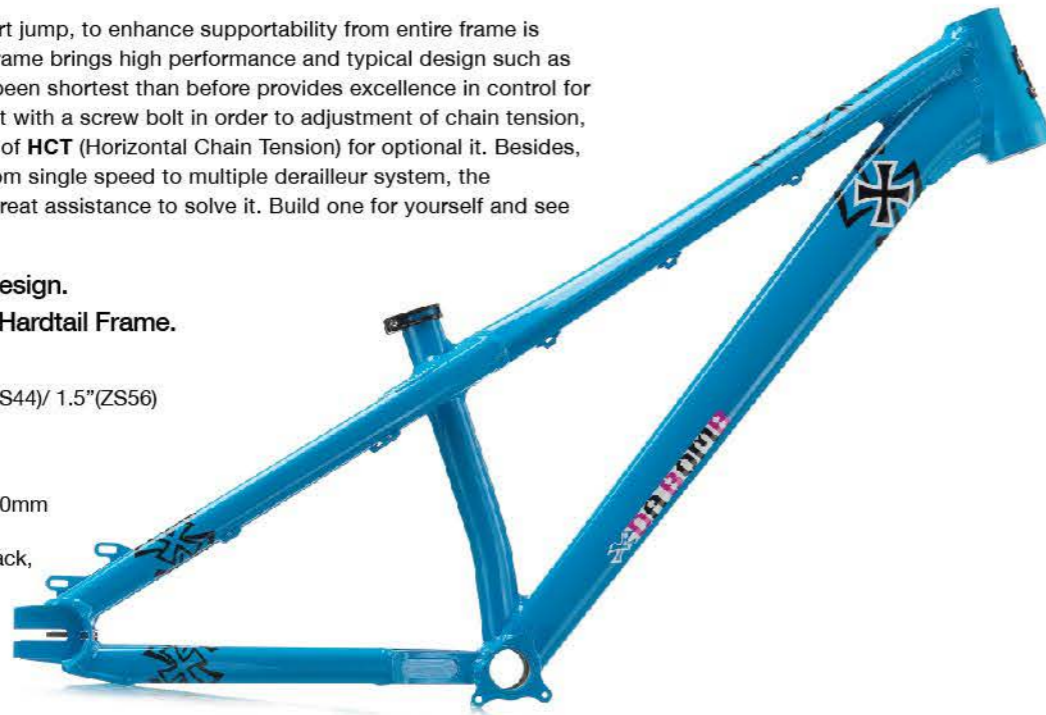

EXPLODE 275

XC

EXPLODE frame made by Hydroformed tubes with square rear stay, it makes frame stiffness and safety, the tapered head tube to have a firmed structure and dropout design come with IS disc brake mount on chain-stay and forged dropout for more powerful brake force. In the XC ride, the EXPLODE will be high performance.

Size: 15", 17", 19", 21"
 Tapered Head Tube 1-1/8"(ZS44) / 1.5" (ZS56)
 BB Width: 68mm
 Seat Post: 31.6mm
 Dropout: IS mount
 Colors Available: Matte Black, Green, Yellow



STRIKER 275

XC

The STRIKER 275 made by Hydroformed aluminum tubes and combine with typical smooth welded padding technology, it appearance looks more streamline and artistic, and brings progressive geometry and flexibility as carbon frame.

Smooth Welding and Padding Frame.
Shaped Rear Stay Tubes.

Size: 15", 17", 19", 21"
 Tapered Head Tube 1-1/8"(ZS44) / 1.5" (ZS56)
 BB Width: 68mm
 Seat Post: 31.6mm
 Dropout: Post mount
 Colors Available: Matte Black w/decal Blue, White, Neon Yellow



IMPACT STEM

MK 26 PLUS DH

MK26 PLUS revised from MK26 is the shortest and super light DH direct mount stem designed for any application of dual crown forks. Different from MK26 design, MK26 Plus Build up connection between "2 pieces" to a firmer "1pc".

The Direct mount by 4 bolts and designed shortest extension.

Material: AL6061-T6 with CNC machined
 Barbore: 35mm
 Extension: 25mm and 30mm
 Angle: 20°
 Weight: 140g
 Color Available: Black, Red



BULLET SHELL DH/FR/DJ

Shorten forged stem for increase strength and durable, the extension 35mm to effectively increased agility and stability in steering.

Material: AL6061-T6 Forged with Polished
 Barbore: 31.8mm
 Extension: 35mm
 Angle: 0°
 Weight: 149g
 Color Available: Silver, Black, Red, Blue



MINIME 33

DH/FR/DJ

MINIME 33 is designed to have the shorter and smaller body for any special trail condition.

Material: AL 6061-T6 CNC machined
 Barbore: 31.8mm
 Extension: 33mm
 Steerer: 1-1/8"
 Weight: 165g
 Color: Black/ Blue, Black/ Gold, Black/ Red



DIRECT MOUNT SPACER

DA BOMB Direct Mount Spacer comes out for diverse gravity center settings, it is assembled directly and easily locked by 4 bolts, 5mm thick 17.6g for each piece, it is usually carried as accessories to set up with MK26 or other applications.

Direct Mount By 4 Bolts.
 Thickness: 5 mm.
 Weight: 17.6g.
 Color Available: Black.



MP8 AM

MP8 is the one to satisfy your dream of your rides while can show your ride-style, the designed exclusively for 650B and 29ER AM/XC bikes and smooth handing experience with shiny made by CNC machined. MP8 provides extraordinary strength and maintenance lightweight features and guarantees the best steering on your ways.

Drop-Bar Design.

Material: AL6061-T6 with fully CNC machined and anodized colors process
 Steerer Dia.: 1-1/8"
 Barbore: Dual sizes available 31.8mm and 35mm
 Extension: Two sizes for option, 60mm and 80mm
 Angle: -17°
 Stack Height: 32mm
 Effective bar clamp height:
 9mm for ext. 60mm;
 15mm for ext. 80mm
 Weight: 148g/60mm; 170g/80mm
 Color Available: Black, Green, Blue



MIG 31 AM-XC

When you glance at this item, you will find its figure just similar a small prototype of battleplane called MIG 31. We combine some ideas as the shorter extension 45mm and the total weight 142g.

Material: AL6061-T6
 CNC machined
 Barbore: 31.8mm
 Extension: 45mm
 Steerer Dia: 1 1/8"
 Weight: 142g
 Color Available: Black, Orange, Red



F35 AM-FR

The F35 is designed to be your best companion on the trails, its lessened extension as 45mm through comes along with weight reduced smartness when directing Your bike, the 35mm barbore is applicable from thicker bar.

Fit For 35mm Handlebar design.
 Material: AL6061-T6 CNC machined
 Barbore: 35mm
 Extension: 45mm
 Steerer Dia: 1 1/8"
 Weight: 154g
 Color Available: Black, Red, Green



FLOATA XC-AM

When it kicks in the light weigh, you can feel how light this stem is. Made with alloy 6061 3D forged that gives you the strong and super light feeling.

Fits 1-1/8" steering tube

Material: AL6061-T6 3D forged
 Barbore: 31.8mm
 Angle: 10°
 Length: 60mm/90mm
 Weight: 141g(60mm) / 147g(90mm)
 Color Available: Black, White



KING AM-FR

Having the king on your bike is really cool and fun. With Anodized colors, the stem looks brighter and not so old school. Weight with only 157g that gives you light feeling. The new 2 in 1 design in 31.8 or 35mm has great strength and more suitable for riders.

Fits 1-1/8" steering tube
 Material: AL6061-T6 CNC machined
 Barbore: 2 in 1 design in 31.8mm or 35mm
 Extension :50mm
 Weight: 157g (shim included)
 Color Available: Black, Blue, Green



HANDLEBAR

BAZOOKA 800 AM-DH



What a badass weapon? The BAZOOKA is always the most wanted toy for boys back to high school and once you own it, then you are the boss.

Material: AL6061 T6 double butted
 Bar Rise: 12.7mm
 Backsweep: 9°
 Upsweep: 5°
 Barbore: 31.8mm
 Width: 800mm
 Weight: 402g



Color Available: Black, Shiny Sliver, Neon Yellow, Royal Blue, Shine Gold, White

APACHE 750 AM-FR

Like the Apache in the air, this handle bar has unlimited power to attack the enemies. Adapting the 6061 T6 heat treated aluminum which gives it more power and strengths.

Material: AL6061 T6 double butted
 Bar Rise: 25.4mm
 Backsweep: 8°
 Upsweep: 10°
 Barbore: 31.8mm
 Width: 750 mm
 Weight: 394g
 Color: Black, White



TACTIC DJ / STREET

If you got the DJ or Street bike, TACTIC will be your best weapon and it will help you to conquer the battle. Due to the super high 3 inches bar rise, the TACTIC is good for SS DJ street. The width of 730mm is easier for riders to do trick which is a big benefit.

Material: AL6061 T6 double butted
 Bar bore: 31.8mm
 Bar Rise: 3"
 Backsweep: 5°
 Upsweep: 9°
 Width: 730mm
 Weight: 393g

Color Available: Sandblast Black, Sandblasted Gold



COBRA XC-AM

The COBRA designed for XC riding strong and enough for AM adventures as well, it is quick and easy to steering.

Material: AL6061 T6 double butted
 Bar bore: 31.8mm
 Bar Rise: 20mm
 Backsweep: 5°
 Upsweep: 6°
 Width: 710mm

Color Available: Barrel Brown, Wasabi Green, Black

Weight: 267g



ARTILLERY ENDURO / AM

Artillery bars are marketed as All-mountain and Enduro, the 740 mm width design with a 9-degree backsweep providing a lower gravity rides, and low 4.8mm rise is a good complement to aggressive trail riding. Artillery is made by hydro-forming that resulting in a weight of 276g only, but structure really bring it stiffness and strengthen.

Low Gravity Design For 29ER or 27.5 Bikes.



Material: AL6061 hydro-forming tube
 Sand blasting with anodized colors
 Rise: 4.8mm
 Backsweep: 9°
 Barbore: 31.8mm
 Width: 740mm
 Weight: 276g
 Color Available: Green, Black

DETONATOR 35 DH / FR

The DETONATOR bar makes perfect for Downhill and Freeride riding, due to barbore design in 35mm keep strong and stiff. These 800mm wide bars with 8-degree backsweep good for aggressive trail riding and the low rise 18mm providing a lower gravity and long rides, although DETONATOR made by double butted but it maintain the weight ,also increased structure for stiffness.

Material: AL 6061 T6 double butted
 Bar bore: 35mm
 Bar rise: 18mm
 Backsweep: 8°
 Upsweep: 6°
 Width: 800mm
 Weight: 397g
 Color: Red, White, Yellow, Blue, Green



BOMB LOOP 4 IN 1

1. INTEGRATED (IS42/IS52). 2. INTERNAL (ZS44/ZS56).
3. For 1.5" TAPERED steering tubes. 4. For 1-1/8" STRAIGHT steering tubes.

For shops only need BOMB LOOP 4 IN 1 to solve so many standards and size.
4 sizes headsets only one set price.
It solves for shops to stock every kind each person needs.
Made by AL6061-T6 aluminum CNC machined.

Bearing: 45 degree
Weight: 135g
Crown races: 30mm & 39.8mm

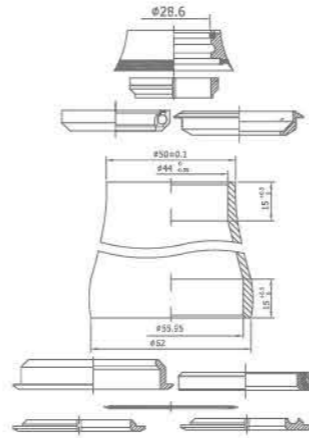

BOMB LOOP EC49

EC49 outer bearing design (ZS44/EC49) to keep forks rolling smoothly for long ride.

Apply to:
SANTA CRUZ: Nomad, Bronson, 5010, Bantam, Superlight, Blur TRC, Highball29.
FELT: Decree, Compulsion.
Made by AL6061-T6 aluminum CNC machined.

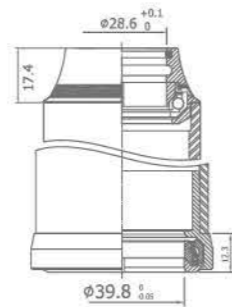

1-1/8" INTEGRATED IS42/IS42

for 1-1/8" fork

Size: IS42/IS42
1-1/8" bearing 45 degree
Made by 6061 T-6 aluminum CNC machined
Weight: 105g

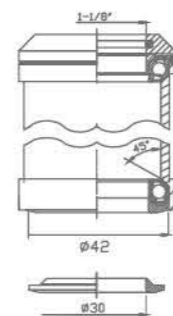

1-1/8" INTERNAL ZS44/ZS44

for 1-1/8" fork

Size: ZS44/ZS44
1-1/8" (28.6mm)
Made by 6061 T-6 aluminum CNC machined
Weight: 110g

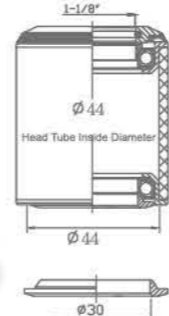

BONBONS LOCK-ON 2.0

MTB

The BONBONS LOCK-ON 2.0 with knobs provide better absorption and smooth, Half-flange designed perfect for shift lever control and good for riders with large hands.
The LOCK-ON 2.0 grip is comfortable during MTB rides.

Alloy Lock-on Clamp

Material: Rubber compound slip-free pattern knobs
Length: 135mm
Weight: 113g
Color Available: Black with orange lock rings
Red with black lock rings



BONBONS DJ/ BMX

The performance of the BON BONS is really great grip, due to the professional design of Knobs which can absorb the impacts very well. When you want to do tricks or some magic, the BONBONS will be easy to conquer.

Rubber compound
ID: 22.2mm
Length: 140mm
Weight: 108g
Color Available: Black, Blue, Orange, Purple, Red



HOLY SHIT 2.0

MTB

Having a cool grip that has skull engraving is not an easy thing and it makes people jealous all the time. Why do we call this Holy Shit?

DaBomb Solid Skull pattern
Alloy double-lock-clamp design
Out layer soft Kraton rubber, inner plastic shell



Length: 130mm
Weight: 100g
Color Available: Black, white



TORPEDOES

XC-ENDURO

Using 3D forged technology to make the post and top clamp in one-piece, this makes the structure stronger. One bolt adjustment design lets you easily mount saddle position & angle in one-time.

Material: AL 6061-T6 3D forged
 Post Length: 400mm
 Offset: 10mm
 Size: 30.9mm and 31.6mm
 Weight: 278g
 Color Available: Black



THRUSTER

XC-DH

THRUSTER is a badass seatpost that weighs only 284g and it is using the 3D forged technology which makes the seatpost stronger. Compared to other seatposts, the THRUSTER comes with 27.2, 30.9 and 31.6mm which give you more options to select.

Material: AL 6061-T6 3D forged
 Post Length: 350mm
 Size: 27.2mm, 30.9mm and 31.6mm
 Weight: 284g
 Color Available: Black

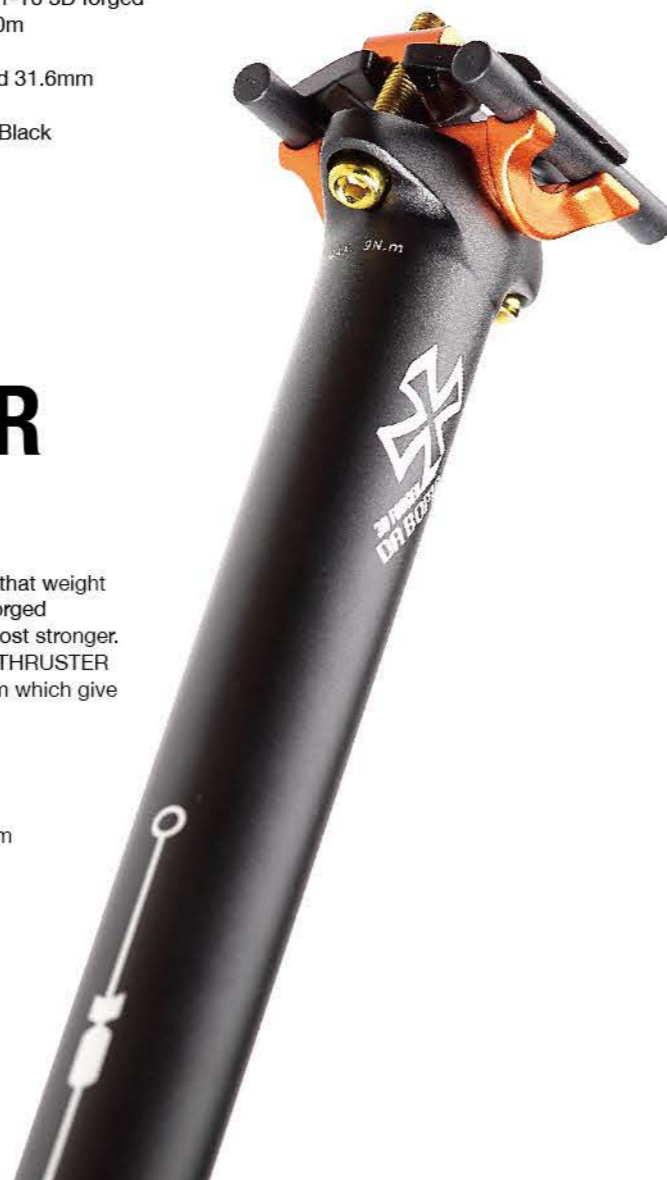

BOMB QR CLAMP 3.0

With the fashionable design - Bomb QR clamp, the surface is done by CNC cutting and sand blasting process, based with trendy colors used and additional effects "MATTE" and "GLOSS" created by anodized process are leaving on its surface to create a clamp exquisite.

CNC machined
 Quick Release seat clamp

Material: AL6061-T6 with CNC machined,
 Anodized and Sand Blasting lever
 Colors: Black, Blue, Red, Green
 Size: ϕ 34.9mm
 Weight: 40g
 Color Available: Black, Blue, Red, Green



MARK 2

The MARK 2 is a new seat clamp in lightweight without burden.

Full CNC machined from AL6061.

Size: 34.9mm
 Weight: 22g
 Color Available: Black, Blue, Red, Silver



BOMB PIN 3.0

Bomb Pin 3.0, its lever is done by CNC cutting and sand blasting process. Based with fashion colors used and additional effects "MATTE" and "GLOSS" created by anodized process are leaving on its surface to make the pin exquisite.

Material: AL6061-T6 with CNC machined, Anodized and Sand Blasting lever CR-MO axle
 Size: 100mm/front, 135mm/rear
 Weight: 85g
 Color Available: Black, Blue, Red, Green



RIM/ WHEELSET



STRAFE EVO

XC-AM

Ultra light REV-275 rims plus straight spoke type hubs STRAFE EVO, the new design hubs with dual seals caps and ENDURO bearings, as more tension than other hubs that would be favorite items by someone who is pursuing more stiffness on bike construction.

REV-275 Rim (Camo) 27.5" (650B) x 28H, Width: 28mm
 STRAFE EVO F-15 (Orange/Black), 15m/m Thru type convert to 9mm QR type.
 STRAFE EVO R-142 (Orange/Black), 12mm Thru type convert to 135mm QR type
 Accpet for 10/11 speeds cassette sprockets. Discbrake hub

Spoke: Black stainless steel 14G
 Weight: 1805g
 Color Available: Camo



REV-275 WHEEL

XC-FR

Use ultra-light as 429g of REV rims, engage STRAFE series hubs with ENDURO bearings to Enhance performance and durability.

REV-275 Rim (Black) 27.5" (650B) x 32H, Width: 26mm
 STRAFE F-15 (Black), 15m/m Thru Type convert to 9mm QR type
 STRAFE R-142 (Black) 10/11 speed Aluminum cassette body Disc brake hub.

Spoke: Black stainless steel 14G
 Weight: 2200g
 Color Available: Black



RIM/ WHEELSET

ADVANCE 275 DH-FR

ADVANCE comes out with technology changed and enhanced strength to create the best stabilized profile, an innovation for stiffness and durability, lightweight, power transfer. Although made of Alloy material but the weight more than lighter before designed and the 35mm width make it perfect for aggressive DH and FR riding.

Material: AL6061-T6
 Size: 27.5" x 32H
 Width (inner/overall): 30mm/35mm
 Height: 19mm
 Weight: 495g/pc
 ERD: 556.5mm
 ETRTO: 584m
 Color Available: Anodized Black, Decals in White, Neon Yellow, Neon Blue

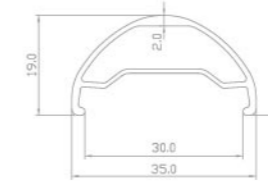

RIM/ WHEELSET



REV-275 CARBON XC-ENDURO

If you are looking for a rim presented lightly, the material of carbon fiber (Toray carbon T800) is fulfilled your demands, this is the material connecting to a structure stiffer and lighter and making your bike stronger. Ultra-light weight design for 650B.

Ultra-light weight design For 650B
 Material: Toray carbon T800 w/ UD finish
 Size: 27.5" x 32H
 Weight: 450g/pc
 Color Available: Matte Black

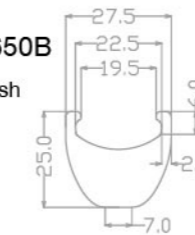

DA BOMB RIM TAPE

Dabomb logo rim tape for 26" rims, 27.5" rims
 Material: High strength tape



REVOLVER 26 DH-FR REV-275 XC-FR

This REVOLVER 26 model has won most Da Bomb fans popular with it for always. Because it reliable, stable and safe. All of the rider loved it.

Material: aluminum rim with stainless steel eyelets
 Size: 26" x 32H
 Width: 32mm
 Weight: 700g/pc
 Colors Available: Golden Camo.

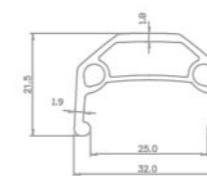

Having the right rim is the most important thing on the road and if the rim is too heavy, It will affect your mood and speed definitely. With the material of alloy 6061-T6, the rim is strong and light which can help you to battle on the road without any problems.

Ultra-light weight design For 650B

Material: AL 6061-T6 w/stainless steel eyelets
 Size: 27.5" x 32H
 Width: 26mm
 Weight: 429g/pc
 Color Available: Black, Golden Camo, Neon Yellow

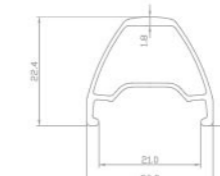

HUBS



STRAFE

The STRAFE is an engineered for durability and simplicity, as well with dual seals good for preventing from dust, sands and water etc intruding, also used **ENDURO** bearings is precision set for rotating smoothly help you keep rolling fast., It is a highly refined hubset for XC,DH,FR,DJ ultimate speed weapon. The models are enclosing F-15+QR, R-142+QR, R-10 and R-150.



F-15 + QR XC-DH Front Hub

2 sealed bearings
Enclose another pair 15mm caps for alternation
Material: AL6061-T6 Forged and CNC machined hubs,
Anodized colors.
O.L.D.: 100mm*(15mm, QR)
Spoke Hole: 32H
2 sealed bearings
Weight: 196g/15mm, 202g/QR
Color Available: Black, Blue, Green
International standard 6 bolts disc brake interface



R-142 + QR XC-FR Rear Hub

4 sealed bearings
Enclose another pair 135mm QR caps for alternation.
with one piece of spacer to accept 10-11 sprocket wheels.
O.L.D.: 142mm*12mm(135mm, QR)
Spoke Hole: 32H
Weight: 314g, 202g/QR
Color Available: Black,
Blue, Green
International standard 6 bolts disc brake interface



142mm rear hub is alternative with 135mm QR side caps which are included in the package, as well as the free hub body is alternative of optional parts SRAM XX1 cassette body (with XX1 specialized caps).

R-10 BOLT-ON TYPE DJ-STREET Rear Hub

STRAFE R-10 is BOLT-ON type especially designed for DJ-Street biker. Accept 10 speed free wheels.
O.L.D.: 135mm*10mm (BOLT-ON)
Spoke Hole: 32H
4 sealed bearings
Weight: 555g
Color Available: Black
International standard 6 bolts disc brake interface



R-148 THRU AXLE DH-FR

The designed come with stiffness and aesthetics. O.L.D.148mm hub fit for 650B plus needed, Dual seals with caps to prevents sands, dust, water..etc from entering the hubs, and using ENDURO bearings for rotating smoother keep rolling fast.

O.L.D.: 148mm*12mm
Hooked spoke type
Spoke Hole: 32H
4 Sealed Bearings
Weight: 323g
Color Available: Black
International standard 6 bolts disc brake interface



R-150 THRU AXLE DH-FR Rear Hub

4 sealed bearings
with one piece of spacer to accept 10-11 sprocket wheels with 150mm width M12 THRU for Heavy duty DH/FR use

O.L.D.: 150mm*12mm
Spoke Hole: 32H
4 sealed bearings
Weight: 337g
Color Available: Black
International standard 6 bolts disc brake interface



Optional parts – 20mm caps

20mm Axle Adaptor
20mm caps for F-15+QR are sold separately.



Optional parts – XX1 cassette body

FOR R-142 + QR
12*142mm



QR-R 142 THRU AXLE AM-FR

The QR-R142 thru axle can adjust the ideal position easily and it's also compatible with Shimano E-thru system.

M12XPitch 1.75 Thru Axle
Weight: 78g
Color Available: Black



R-150 THRU AXLE DH

DaBomb has added the Strafe R-150 AXLE to the family and it is for 12mmx150mm hub.

Color Available: Red



SADDLES

ASPECT XC

ASPECT has low profile design giving XC bikers the realest feelings, PU design makes the saddle looks pretty cool, material density foaming fabric strengthens its structure and gives bikers more cozy rides.

Low profile design

Material: High frequency embossing PU Cover, nylon fiber injection base, high Density foam.
CrMo Rail: 7mm w/dual color process
Weight: 241g
Color Available: Black, Neon yellow, White



ZAP DJ

The key point to win the battle is to have a good saddle that can tied you up on the bike and zapping the enemies for you. ZAP comes with anti-slip material that doesn't slide you away and it weights only 257g.

Anti-slip Suede material covered

Material: PU Synthetic leather (white)/ Suede (black)/ Suede (Blue)Cr-Mo Rail: 7mm
Weight: 251g (black/blue) 257g (white)
Color Available: Black, White, Blue



DA SKULL 2.0

We don't care what symbol you have on your saddle but we can tell the Dabomb DaSkull saddle is definitely an exclusive saddle that's has cool SKULL symbol on the market. Featuring with ultra strong Cr-Mo rails, you don't have to worry the strength since today.

Low Profile Aero Shape
Lightweight Saddle

CrMo Rail: 7 mm
Weight: 269g
Color: White



BOOSTER

Different from universe saddles, the rear section of the saddle is raised as the new design from DA BOMB to ensure your bottom covered and avoided from slippery. Stylish bumper sewed on the connection of fabric and chassis is reinforcing entire structure.

Enlarged chassis
Stylish bumper
Raised to the rear portion

CrMo Rail: 7mm w/dual color process
Weight: 250g
Color Available: Camo, Black, Streak



PEDALS

V STAGE MTB

The designed combined in double side for MTB Clip-in and flat, it have double function available for Your needed it. V STAGE has been upgraded with innovative technologies of bearing LSL bushing and seal system to prevent water and dust from entering the pedal, it would be bring high performance and reliability.

CNC Machined Pedal
Sealed Bearing
Super Thin Type
For Shimano CLIP system

Material: AL 6061-T6 with CNC machined.
Size (Platform): 100*110mm
Bearing: LSL bushing & sealed
Weight: 467g/pair
Color Available: Black, Blue, Red



BULLET CLIP XC-DH

Free vent design prevents water and dirt intrude from outside to last BULLET CLIP's life. Each side of one piece BULLET CLIP has 10pcs traction pins removable by the wrench included in the package. BULLET CLIP is offering you a more peaceful pedaling due to technological design of each piece pedal improved by two sealed bearings and one DU.

Free vent design.
CNC Machined Extreme Thin Pedal.
Replaceable Pins and with Convenient Wrench included.

Material: AL 6061-T6 with CNC machined.
Size (Platform): 97*108mm
Thickness: 10mm
Weight: 356g/pair
Color Available: Black, Blue, Red



SHOOT BLOCK XC-DH

SHOOT BLOCK made by die cast is more affordable for bikers, if someone has personal budget to get new stuffs decorating the bike, SHOOT BLOCK is the best choice for you. Diamond grain surface is for both reducing scrapes caused and getting quality enhanced, non-scrapping and anti-slippery pins engaged for bikers having more safe ridings.

Die Casting and Extreme Thin Pedal.
Replaceable anti-slippery steel Pins with a Convenient Wrench included.

Material: AL 6061-T6 ED coating colors,
PAD printing logo
Size (Platform): 100*105mm
Thickness: 9mm
Weight: 352g/pair
Color Available: Matte Black, Gloss Red, Gloss Blue, Raw



FIREBALL XC-DH

Fireball pedal made by alloy material and replaceable pins that give you the best feeling to step on, it doesn't matter whether you are going up or going down, the FIREBALL will be your best weapon.

Die Casting Pedal.
Super Economy Pedal.

Material: Alloy (One-piece)
Size (Platform): 100*105mm
Thickness: 21mm
Weight: 456g/pair
Color Available: Black, Neon Yellow



GSX+X-GUARD

AM-ENDURO

When designed GSX, our objective was obvious that kept the item lighter without sacrificing its function. GSX is especially compatible with narrow-wide chainring (X-RING) to get maximum efficiency, GSX guides chain more smoothly without getting extra unnecessary rolling resistance.

Lightweight design
For narrow-wide chainring

9-11 speed
Chain ring capacity: 30T-36T
Chain guide system: I.S.C.G 05
Color: Black
Weight: 47g



BCD: 104mm Max. 36T
Chain ring capacity: 36T
Weight: 45g

X-GUARD

This segmented bash guard is covering a quarter of your chainring and simply mount on where you are going to need it. If somebody is doubt how this bash going on if not fully covers your chainring... Well, the answer will be obvious after you mounting the item on.

AL6061-T6 CNC machined with Anodized colors

GS - D AM

AL6061-T6 CNC machined with Anodized colors

As the designs of the roller is broader and is using material as soft as possible, since DA BOMB was considering to upgrade GS-D on the achievement of reducing and avoiding from unnecessary frictions, resistance and noise.

Lightweight design For dual chain wheel
Avoid from unnecessary vibration and chain offset

Chain ring capacity: 22T-38T
Chain guide system: I.S.C.G 05
Color: Black
Weight: 77g



CGS - G

AM-DH

Jumping Bike Kits New Chain Guide with guard plate to prevent hitting

9-11 speed
Chainguide system: I.S.C.G 05
Chain ring capacity 32T to 40T
Weight: 259g
Color: Black



BGS

AM-DH

Chainring with bashguard Type
(Need to be assembled with bashguard)
CNC aluminum body

9-11 speed
Chain guide system : I.S.C.G 05
Chain ring capacity : 32T to 40T
Weight: 152g
Color: Black
* The item does not include bashguard.



X - RING

Engage narrow-wide teeth to prevent from the situation of chain dropping off or offset. Special design at 30 teeth X-ring that nuts shaped in once piece, so what you have to Prepare is only 4 bolts to simply and directly lock the x-ring on your bike.

Narrow-wide chainring
Nut shaped in one piece for 30T sprocket design

Material: AL7075-T6 CNC machining with anodized colors.
Teeth: 30T, 32T, 34T, 36T
BCD: 104mm.
Weight: 38g/30T, 49g/32T, 67g/34T, 85g/36T,
Color Available: green, blue, black



SCROLL DH

While you are riding into the Downhill and would like seek down in fast, SCROLL can in place of Sprocket from 10 speed to 7 speed, since lightweight design can reduce heavy wear on the sprocket. It's made by CNC machined with anodized process bring it stiffness and strengthen, SCROLL is a great assistance to make your bike get rid of complicated shifts and have more responsive shift system left. The design is not only for mountain bikes but also good for road bikes when you pursuit speed.

Material: AL6061-T6, CNC machining with anodized process.
Compatialble with SHIMANO system:
MTB: Deore XT, XTR
Road Bike: 105, Ultegra, Dura-Ace
Application:
MTB: ranged after 19T sprocket.
Road Bike: ranged after 24T sprocket.
Weight: 39g
Color Available: green, blue, red, black

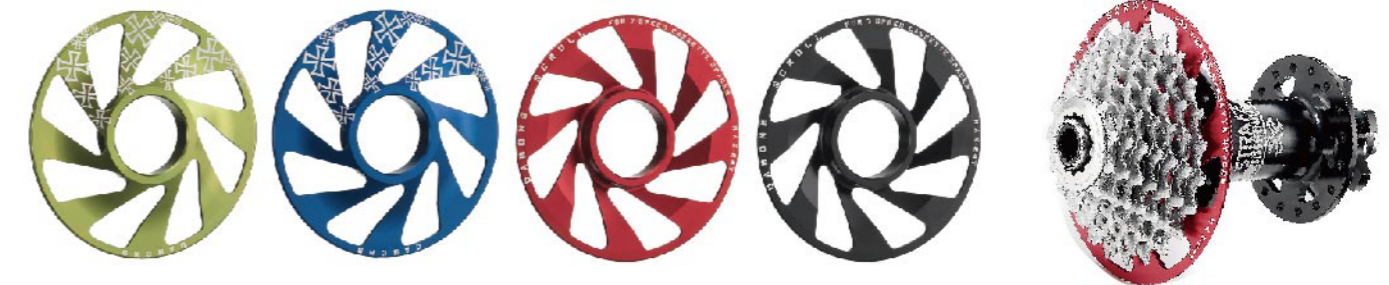

SPROCKET 42T/40T

A faultless of 16T & 40T/42T sprockets good for upgrade 10-speed system, the 16T is impersonate competent actor instead of 15T and 17T. 40T/42T enclosed after 11T-36T cassette is also compatible with Shimano 10 speed drivetrains system, not only easily to installation but also have great durability and the best gear ratio arranged.

Suggest suit for 10-Speed system:
11-13-16-19-21-23-26-30-34-40
11-13-16-19-21-24-28-32-36-42
40/42T Spec:
Sprocket material: 7075-T6 CNC machined

weight: 72g (40T)78g (42T)
Color Available: blue, green
16T Spec:
Sprocket material: Chrome Steel
Weight: 23g
Color Available: gold

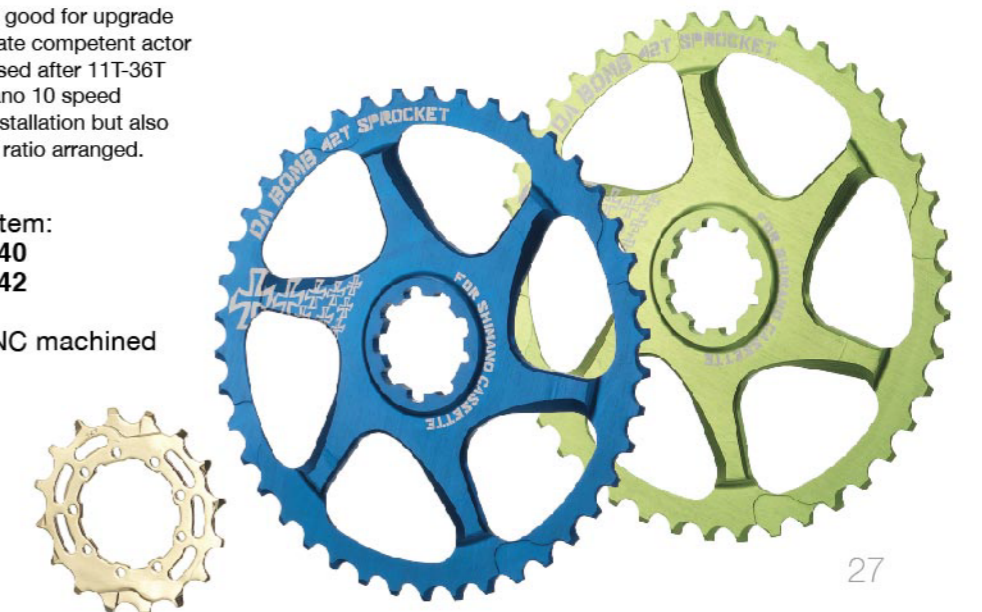

11 TO 2 SINGLE SPEED SPROCKET KIT

DIRT JUMP

The 11 to 2 Single speed sprocket kit fit for multi cassette (9/10/11) speeds convert to single speed kits, this Double Sprocket Kit is the creative product for riders as they want to change gear either 14T or 18T. but it don't like flip flop hub need to remove the wheel.

Material: AL7075 with CNC machined.
 14T & 18T Material: 7075
 Spacers: 2pcs
 Lock Ring: 38mm (12T)
 Color Available: Black, Red



RL-4

STREET / DIRT JUMP

Chain Tensioner
 New micro adjustable roller system multi-segment tension adjustment convert a vertical drop-out frame to single speed.

Weight: 86g
 Color Available: Orange



RL-5

STREET / DIRT JUMP

Chain Tensioner
 New micro adjustable roller system multi-segment tension adjustment in order to reduce noise and vibration, RL-5 an upgrade version from RL-4 TO adopt springs reflecting higher tension on chaining.



HCT STREET/DIRT JUMP



New logo
 Horizontal Chain Tensioner
 For horizontal drop-out system

Weight: 71.5g

D - HANGER

STREET/DIRT JUMP

When you are facing a problem of assembling a rear derailleur on a horizontal dropout, D-HANGER would be a great assistance to solve the problem.

Size: 10mm axle



PROTECTOR RING

The significant utility of these colorful rings is defending your bike's chain stay or Entire frame (available for road/offroad bikes) from attacks of rocks without scratches covered.

Color Available: Black, Red, Neon Green, Neon Pink



BEANIE

Someone said "Fine clothes make the man", just like wearing BEANIE show your personal style, it's design come with fashion and cool ,especially BOMB BOY appeared on it, he will always along side with you to anywhere.

Size: F
 Color Available: Black
 Pattern: DA BOMB, BOMB BOY
 Material: 39% acrylic, 39% wool, 20% polyester, 2% elastic



BANNER

DA BOMB precision hardware banner
 Size: L:200cm x W:50cm
 Color Available: Black, Yellow

BOMB FENDER

XC-DH

BOMB FENDER is a muck catcher to prevent and protect your bike from mud splashed or avoid from muddy shock problem. This portable and designed blade is extra light and thin, simple installation and un-installation between any specific occasions.

Color Available: Black, White



TEAM JERSEY

Color Available: Yellow
 Size: M/L



DABOMB TEE

The Cross color: Black Color
 The Bomb color: Black, Brown, Purple
 Size: M/L



BOMB BOY WATER BOTTLE

If you ride DaBomb and want to be like the Bomb man, you got to have the cool Dabomb water bottle.

100% leakproof design
At 700ml, Ideal for the thirstier sports person!
Made from Low Density Polythene (LDPE) with BPA free
Pull-top sipper cap
Easy-to-handle, non-slip shape

Temp: -5 to 50°C
Color Available:
Moon Silver
Sun Yellow



SKULL VALVE

If you want to scare the enemies on the road, having some skull valve on your wheels can give you huge power and safety.



STICKER SET

DA BOMB sticker set, specs stickers/ pack.



GRENADE VALVE

When you got pissed of f at the race, the grenade valve definitely will be your best choice to throw at the enemies.

Da Bomb exclusive grenade valve
Suitable for Schrader (American) valves
Color Available: Silver/Red/Blue/Orange



CROSS VALVE

Suitable for Schrader (American) valves
Color: White
Da Bomb Cross Logo
Suitable for Schrader (American) valves
Color Available: Black



AUTHORIZED DEALER STICKER

Can't afford to lose the chance to have authorized dealer sticker and if you missed it, you will regret it.
3pcs stickers/ pack.

FOR SHOPS/ FANS
Size: W210xH150 mm

FOR VANS/ FANS
Size: W210xH290 mm



FRAME GEOMETRY CHART

WHO HAS THE BEST WEAPON

WARNING

Bicycle must be assembled and checked regularly by a qualified mechanic. Always wear appropriate safety gear. AND LISTEN TO YOUR MOTHER!

DA BOMB 2017 FRAME GEOMETRY CHART

Model Name	Riding style	Frame Travel	Size (C to T)	Head Tube Angle	Seat Tube Angle	Horizontal Top Tube Length	Chain Stay Length	B.B. Height	Wheel Base Length	Head Set Size	Seat Post Size	Suggested Fork Travel
FOAB BOMBS 26	DOWNHILL	8"	26x16.5"	63.5°	70.6°	590 mm	435/445 mm	342 mm	1214 mm	ZS44 / ZS56	30.9 mm	180-200 mm
FOAB BOMBS 27.5	DOWNHILL	8"	27.5x16.5"	63°	70.1°	591 mm	445 mm	345 mm	1233 mm	ZS44 / ZS56	30.9 mm	180-200 mm
BLITZ 5.5	ENDURO	5.5"	17"	70.6°	69.7°	592 mm	435 mm	355 mm	1121 mm	ZS42 / ZS52	31.6 mm	120-160 mm
	ALL MOUNTAIN	5.5"	19"	70.6°	69.6°	612 mm	435 mm	355 mm	1141 mm	ZS42 / ZS52	31.6 mm	120-160 mm
EMP ATTACK 26	ALL MOUNTAIN	5.4" / 4.7"	26x16"	68°	71°	570 mm	435 mm	342 mm	1134 mm	ZS44 / ZS56	30.9 mm	120-160 mm
	ALL MOUNTAIN	5.4" / 4.7"	26x18"	68°	71°	600 mm	435 mm	342 mm	1164 mm	ZS44 / ZS56	30.9 mm	120-160 mm
EMP ATTACK 27.5	ALL MOUNTAIN	5.4" / 4.7"	27.5x16"	68°	69°	560 mm	435 mm	330 mm	1123 mm	ZS44 / ZS56	30.9 mm	120-160 mm
	ALL MOUNTAIN	5.4" / 4.7"	27.5x18"	68°	69°	585 mm	435 mm	330 mm	1148 mm	ZS44 / ZS56	30.9 mm	120-160 mm
EMP 29ER	ALL MOUNTAIN	4.2"	29x18"	69°	71°	600 mm	448 mm	314 mm	1146 mm	ZS44 / ZS56	30.9 mm	100 mm
REVOLUTION	SLOPE STYLE	4"	26x 13.5"	69°	70°	575 mm	420 mm	327 mm	1082 mm	ZS44 / ZS56	30.9 mm	80-120 mm
SONIC BOOM	4X/ DJ	Hard Tail	26x12.4"	69.5°	73.3°	571 mm	378 mm	314 mm	1026 mm	ZS44 / ZS56	30.9 mm	80-120 mm

OEM MODELS

Model Name	Riding style	Frame Travel	Size (C to T)	Head Tube Angle	Seat Tube Angle	Horizontal Top Tube Length	Chain Stay Length	B.B. Height	Wheel Base Length	Head Set Size	Seat Post Size	Suggested Fork Travel
STRIKER 27.5	XC	Hard Tail	27.5x15"	70.5°	68.2°	595 mm	445 mm	300 mm	1096 mm	IS44 / IZ56	31.6 mm	80- 100 mm
	XC	Hard Tail	x17"	70.5°	68.2°	595 mm	445 mm	300 mm	1096 mm	IS44 / IZ56	31.6 mm	80- 100 mm
	XC	Hard Tail	x19"	70.5°	68.2°	595 mm	445 mm	300 mm	1096 mm	IS44 / IZ56	31.6 mm	80- 100 mm
	XC	Hard Tail	x21"	70.5°	68.2°	595 mm	445 mm	300 mm	1096 mm	IS44 / IZ56	31.6 mm	80- 100 mm
EXPLODE 27.5	XC	Hard Tail	27.5x15"	70.5°	66.4°	597 mm	445 mm	300 mm	1092 mm	IS44 / IZ56	31.6 mm	80- 100 mm
	XC	Hard Tail	x17"	70.5°	66.4°	597 mm	445 mm	300 mm	1092 mm	IS44 / IZ56	31.6 mm	80- 100 mm
	XC	Hard Tail	x19"	70.5°	66.4°	597 mm	445 mm	300 mm	1092 mm	IS44 / IZ56	31.6 mm	80-100 mm
	XC	Hard Tail	x21"	70.5°	66.4°	597 mm	445 mm	300 mm	1092 mm	IS44 / IZ56	31.6 mm	80-100 mm